

Kestrel®
Rely on us.

NatureClad®

FEEL THE GREAT OUTDOORS



I N S T A L L A T I O N G U I D E

NatureClad

The NatureClad range offers the customer a choice of 2 styles, with a comprehensive range of components, trims and fixings for each type.

They present the ideal substitute for timber claddings, with the added advantages of attractive appearance, low maintenance qualities, weather resistance and durability.

In addition, they can significantly improve the thermal performance of buildings, particularly when combined with insulation.

Composition and manufacture

NatureClad Cellular PVC is an extruded, foamed material with an integral smooth and durable skin. The product can be cut, drilled, nailed and routed, using conventional tools. It is light to handle, easy to fix and does not require any painting or subsequent treatment after installation. Finished with a protective PVDF layer, the NatureClad range is easy to clean, low maintenance and will look great for years to come.

Advantages

- Durable and easy to clean
- Weather resistant
- Thermally efficient
- Low maintenance
- Compatible with other building materials
- Will not warp, flake or peel
- Rot proof
- Will not support bacterial or fungal growth
- Lightweight and quick to install

Environment and recycling

NatureClad Cellular PVC Cladding products represent an environmentally responsible use of plastics.

They do not contain CFCs, lead or cadmium, which are considered harmful to the environment. Also, they have a very long life span and when replaced, can be easily identified and fully recycled.

Standards

NatureClad is manufactured to stringent quality control standards:

- BS EN ISO 9001 - Quality Management
- BS EN ISO 14001 - Environmental Management
- BS EN ISO 45001 - H & S Management
- BS EN ISO 50001 - Energy Management
- BES 6001 - Responsible Sourcing



The installation guidance detailed in this document will help you to install NatureClad, whilst ensuring you meet our high standards of quality.

Components

The surface of NatureClad has a high resistance to heat absorption which permits the product range to be installed using the standard installation instructions of light-coloured textured cladding.

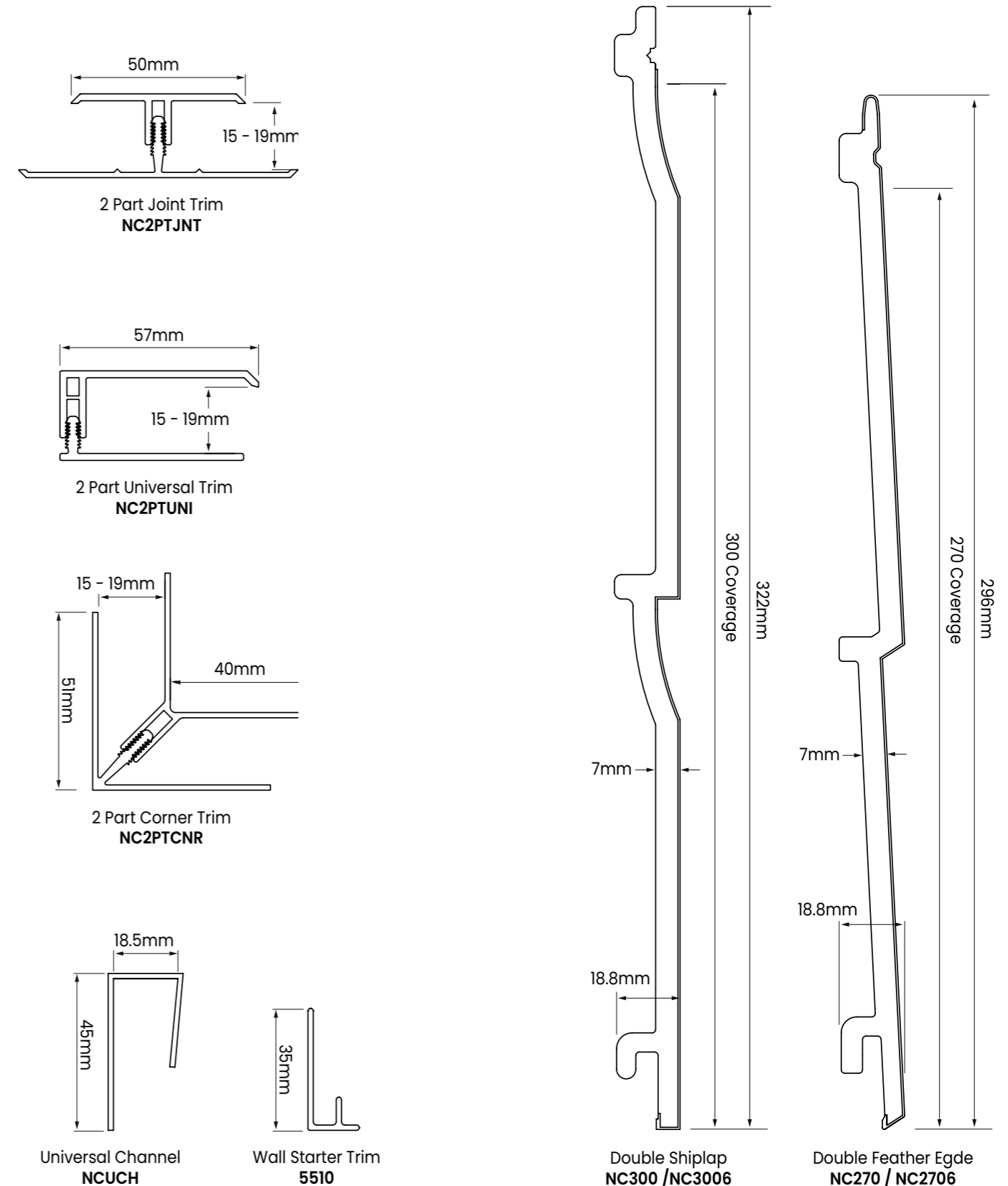

Horizontal Installation

Battens

- Tanalised Timber 25mm x 38mm installed vertically.
- Max centres of 300mm.
- Battens to be Parallel, Straight and Plumb.

A 25mm x 38mm tanalised timber batten installed horizontally is required at the top of the installation.

There is no requirement for a horizontal batten at the base of the installation which should remain open to allow for moisture and air flow.

Membrane

A breather membrane must be installed between the battens and the substrate when the substrate is not water resistant.

Trim Installation

A **Starter Trim** is secured to the battens at the base of the installation with 25mm A4 stainless steel pins.

Consideration should be given to the overhang of the Cladding Plank from the bottom of the Starter Trim. (NC300 = 10.5mm & NC270 = 14.5mm)

The vertical **Edge/Corner trims** are installed by cutting out a section of the rear of the trim to fit around the Starter Trim, securing with 25mm A4 stainless steel pins at maximum 300mm intervals. Trims should be straight and plumb and the full height of the installation.

The male trim of the horizontal **2-part Top Edge Trim** is then installed between the two vertical trims at the top of the installation.

When an installation requires a mid-point joint a 2-part Joint Trim must be used. There are no individual Butt Joints within the NatureClad system.

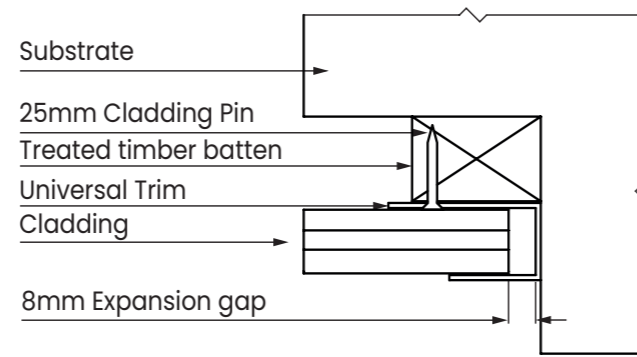

Universal Trim - Horizontal Installation

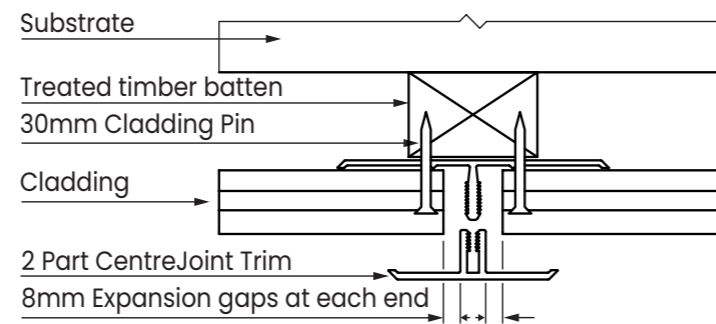

Two Part Joint Trim - Horizontal Installation

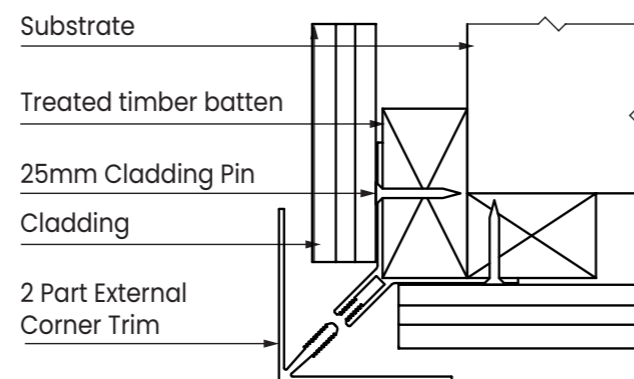

Two Part External Corner - Horizontal Installation

Cladding Plank Installation

The first cladding plank is installed by locating the rear leg of the plank into the channel of the Starter Trim and positioned to allow an 8mm expansion gap at each end. The plank should be checked for level before securing with 30mm A4 stainless steel Cladding Pins through the nailing line in the plank. Note: The next cladding plank should cover the fixings of the first plank - 'Secret Fix'.

3mm x 30mm stainless steel screws may be used as an alternative to 30mm Cladding Pins.

The second Cladding Plank is interlocked with the first plank and positioned to allow an 8mm expansion gap at each end before securing with the same fixings as previously used.

Follow this procedure up until the last plank, checking that each plank covers the previous planks fixings and that each plank is fully engaged and level.

The final plank will need to be cut down to fit the gap between the top of the last Cladding Plank and the male firtree on the Top Edge Trim. An allowance should also be made for the female firtree to allow the male and female parts of the 2-part Top Edge Trim to engage.

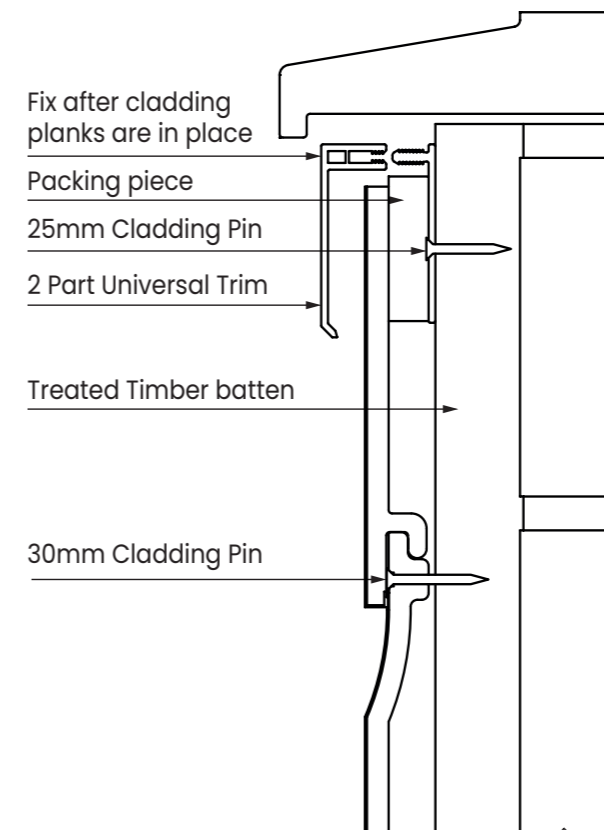

Two Part Universal Trim - Horizontal Installation

The cut down top plank will need to be packed using material off-cuts, to ensure the outer face of the plank remains vertical. Secure the top plank using the pins or screws.

The final stage of installation is to cut and secure the second part of 2-part Trims.

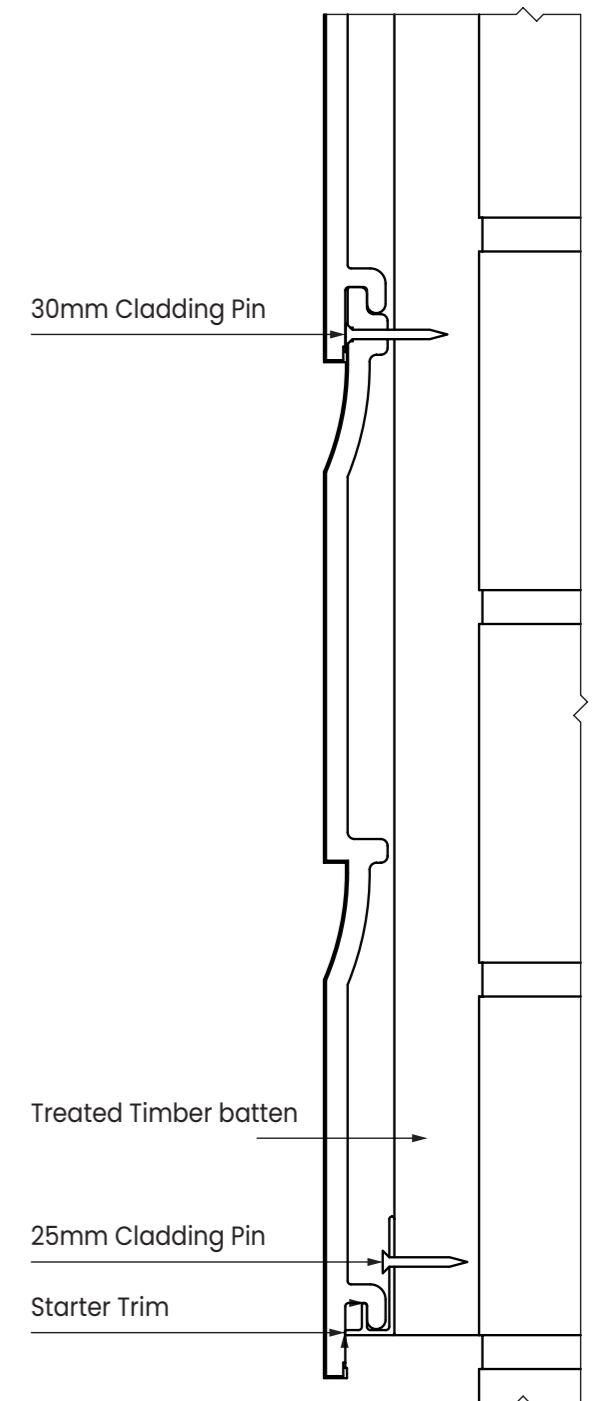

Starter Trim - Horizontal Installation

Vertical Installation

Battens

- Tanalised Timber 25mm x 38mm installed vertically –max 600mm centres.
- A second row of Tanalised Timber 25mm x 38mm installed horizontally –max 300mm centres.
- Battens to be Parallel, Straight and Level.

A 25mm x 38mm tanalised timber batten installed horizontally onto the first row of battens is required at the top and bottom of the installation.

The use of two rows of battens set at 90° (cross battens) provides an air gap to allow for moisture and air flow.

Membrane

A breather membrane must be installed between the vertical battens and the substrate when the substrate is not water resistant.

Trim Installation

A Universal Channel is secured to the batten at the base of the installation with 25mm A4 stainless steel pins at maximum 300mm intervals. The channel should have 30mm x 4mm slots at 1m intervals to allow for drainage. As a simple alternative it is possible to install without a trim along the bottom edge.

The vertical Edge/Corner trims should be 2-part versions and are installed by cutting out a section of the rear of the trim to fit around the Universal Channel, securing with 25mm A4 stainless steel pins at maximum 300mm intervals. Trims should be straight and plumb and the full height of the installation.

The male trim of the horizontal 2-part Top Edge Trim is then installed between the two vertical trims at the top of the installation.

Cladding Plank Installation

The first cladding plank is installed by locating the plank into one of the 2-part vertical trims and positioned to allow an 8mm expansion gap at each end. The plank should be checked for plumb before securing with 30mm A4 stainless steel Cladding Pins through the nailing line in the plank. Note: The next cladding plank installed should cover the fixings of the first plank – ‘Secret Fix’.

3mm x 30mm stainless steel screws may be used as an alternative to 30mm Cladding Pins.

The second Cladding Plank is interlocked with the first plank and positioned to allow an 8mm expansion gap at each end before securing with the same fixings as previously used.

Follow this procedure up until the last plank, checking that each plank covers the previous planks fixings and that each plank is fully engaged and plumb.

The final plank will need to be cut down to fit the gap between the edge of the last Cladding Plank and the firtree on the 2-part Trim. An allowance should be made to allow the male and female parts of the 2-part Trim to engage.

The cut down top plank will need to be packed using material off-cuts, to ensure the outer face of the plank remains in line with the other planks. Secure the plank using the pins or screws.

The final stage of installation is to cut and secure the second part of 2-part Trims.

Diagonal Installation

Battens

As per horizontal installation with max batten centres reduced to 210mm

Membrane

A breather membrane must be installed between the battens and the substrate when the substrate is not water resistant.

Trim Installation

A Universal Channel is secured to the battens at the base of the installation with 25mm A4 stainless steel pins. The channel should have 30mm x 4mm slots at 1m intervals to allow for drainage. As a simple alternative it is possible to install without a trim along the bottom edge.

The vertical Edge/Corner trims are installed by cutting out a section of the rear of the trim to fit around the Universal Channel, securing with 25mm A4 stainless steel pins at maximum 300mm intervals. Trims should be straight and plumb and the full height of the installation.

The male trim of the horizontal 2-part Top Edge Trim is then installed between the two vertical trims at the top of the installation.

Cladding Plank Installation

The first cladding plank is installed by locating the plank into one of the vertical trims and the Universal Trim, positioned to allow an 8mm expansion gap at each end. The plank should be checked for position before securing with 30mm A4 stainless steel Cladding Pins through the nailing line in the plank.

3mm x 30mm stainless steel screws may be used as an alternative to 30mm Cladding Pins.

The second Cladding Plank is interlocked with the first plank and positioned to allow an 8mm expansion gap at each end before securing with the same fixings as previously used.

Follow this procedure up until the last plank, checking that each plank covers the previous planks fixings and that each plank is fully engaged by checking for level.

The final plank will need to be cut down to fit the gap in the top corner. An allowance should also be made for the male and female parts of 2-part Top Edge Trim to engage.

The final stage of installation is to cut and secure the second part of 2-part Trims.

Kestrel[®]
Rely on us.

NatureClad[®]
FEEL THE GREAT OUTDOORS

®

Kestrel[®]
Rely on us.

Kestrel, Billet Lane, Normanby Enterprise Park, Normanby Road, Scunthorpe, North
Lincolnshire, DN15 9YH

01724 400500

kestrelbp.co.uk